



SAILING INSTRUCTIONS Open Dutch Championship

Olympiajoi class

organised by **GWV De Vrijbouter**

under the auspices of the Royal Netherlands Yachting Union (RNYU)
from August 31st to September 2nd 2018

location: Oud Loosdrecht, The Netherlands

[DP] denotes a rule for which the penalty is at the discretion of the Protest Committee

[NP] denotes that a breach of this rule will not be grounds for a protest by a boat.

[SP] denotes a rule for which a standard penalty may be applied by the race committee without a hearing”

1. RULES

1.1 The regatta will be governed by the rules as defined in *The Racing Rules of Sailing (RRS)*.

1.2 The ‘Rules for Championships Sailing, Windsurfing and Kiteboarding’ will apply.

1.3 Racing rule(s) A4, A5, 33, 62.1, 35, 61.1(b), 66, 62.2, 65.2 and 70.5 (a) will be changed.

1.4 Spare.

1.5 If there is a conflict between languages the English text will take precedence.

1.6 Every person on board who has its domicile in the Netherlands shall have the required license.

1.7 Spare.

2. NOTICES TO COMPETITORS

Notices to competitors will be posted on the official notice board(s) located at Information desk at GWV De Vrijbouter.

3. CHANGES TO SAILING INSTRUCTIONS

Any change to the sailing instructions will be posted before 09:00 on the day it will take effect, except that any change to the schedule of races will be posted by 20:00 on the day before it will take effect.

4. SIGNALS MADE ASHORE

4.1 Signals made ashore will be displayed at the starting tower.

4.2 When flag AP  is displayed ashore, ‘1 minute’ is replaced with ‘not less than 30 minutes’ in the race signal AP.

5. SCHEDULE OF RACES

5.1 Dates of racing:

Date

31st of August: 3 races

1st of September: 4 races

2nd of September: 3 races



5.2 The regatta will consist of a qualifying series and a final series if the number of entries are 45 or more. Appendix K of these sailing instructions applies.

5.3 The scheduled time of the warning signal on the first day is 11:25; for the other days it is 09:55.

5.4 To alert boats that a race or sequence of races will begin soon, an orange flag will be displayed with one sound for at least four minutes before a warning signal is displayed.

5.5 On the last day of the regatta no warning signal will be made after 15:00.

6 CLASS FLAGS

Class flags will be:

Olympiajoi: flag W

7 RACING AREAS

Attachment A shows the location of racing areas.

8 THE COURSES

8.1 The diagrams in Attachment B show the courses, including the approximate angles between legs, the order in which marks are to be passed, and the side on which each mark is to be left

8.2 Spare.

9 MARKS

9.1 Marks of the course are cylindrical inflatable buoys with numbers 1, 2, 3, 4, and 5. Marks 1, 4 and 5 are yellow. Marks 2 and 3 are orange.

The starting marks are a staff with an orange flag aboard of the starting vessel at the starboard side and a staff with an orange flag at the port side of the starting line.

The finishing marks are a staff with an orange flag aboard of the starting vessel at the port side and a staff with an orange flag at the starboard side of the finishing line.

10 AREAS THAT ARE OBSTRUCTIONS

Spare.

11 THE START

11.1 Races will be started by using RRS 26 with the warning signal given 5 minutes before the starting signal.

11.2 The starting line will be between a staff displaying an orange flag on the starting vessel at the starboard- end and an orange flag at the port-end starting mark.

11.3 Boats whose warning signal has not been made shall avoid the starting area during the starting sequence for other races.

11.4 A boat starting later than 4 minutes after her starting signal will be scored Did Not Start. This changes RRS A4 and A5 .

12 CHANGE OF THE NEXT LEG OF THE COURSE

12.1 To change the next leg of the course, the race committee will move the original mark (or the finishing line) to a new position. Changes of positions of marks will not be displayed. This changes Rule 33.



13 THE FINISH

The finishing line will be between staffs displaying orange flags on the finishing marks.

14 PENALTY SYSTEM

14.1 Spare.

14.2 Spare.

14.3 Spare.

14.4 If the jury is on the water jury members will protest if they observe a break of a rule if the parties concerned are not taking a penalty or protest boats concerned.

15 TIME LIMITS AND TARGET TIMES

15.1 Time limits are as follows:

Time limit Mark 1	time limit	target time
<i>30 minutes</i>	<i>75 minutes`</i>	<i>50 minutes</i>

If no boat has passed Mark 1 within the Mark 1 time limit the race will be abandoned.

15.2 Failure to meet the target time will not be grounds for redress. This changes RRS 62.1(a).

15.3 Boats failing to finish within 15 minutes after the first boat sails the course and finishes will be scored Did Not Finish without a hearing. This changes RRS 35, A4 and A5.

16 PROTESTS AND REQUESTS FOR REDRESS

16.1 Protest forms are available at the race office. Protests and requests for redress or reopening shall be delivered there within the appropriate time limit.

16.2 For each class, the protest time limit is 60 minutes after the last boat has finished the last race of the day or the race committee signals no more racing today, whichever is later. After the last qualifying race the protest time is 60 minutes after the last boat has finished the race.

16.3 Notices will be posted within 30 minutes of the protest time limit to inform competitors of hearings in which they are parties or named as witnesses. Hearings will be held in the jury room, located at the first floor above the race office.

16.4 Notices of protests by the race committee, technical committee or protest committee will be posted to inform boats under RRS 61.1(b).

16.5 Spare.

16.6 After the last qualifying race a request for reopening a hearing shall be delivered

- (a) within the protest time limit if the party requesting reopening was informed of the decision on the previous day;
- (b) no later than 30 minutes after the party requesting reopening was informed of the decision on that day.

This changes RRS 66.



16.7 On the last scheduled day of racing [and after the last qualifying race] a request for redress from a protest committee decision shall be delivered no later than 30 minutes after the decision was posted. This changes RRS 62.2.

16.8 A request for a decision in writing has to be delivered within one hour after the decision is given verbally. This changes RRS 65.2 .

16.9 A request for correction of an error in the published results has to be delivered within the protest time limit of the last scheduled day of racing or within 60 minutes after posting of the results, if this is later. When the request is not granted, the protest time limit is 60 minutes after the boat is informed that the request is not granted. This changes RRS 62.2 .

16.10 Decisions of the protest committee in the qualifying races will be final as provided in RRS 70.5. The RNWA has granted permission in accordance with RRS 70.5(a) and the prescriptions of the RNWA to this rule.

17 SCORING

17.1 Four races are required to be completed to constitute a series.

17.2 (a) When fewer than 5 races have been completed, a boat's series score will be the total of her race scores.

(b) When 5, 6, 7 or 8 races have been completed, a boat's series score will be the total of her race scores excluding her worst score.

(c) When 9 and 10 races have been completed, a boat's series score will be the total of her race scores excluding her two worst scores..

17.3 Spare.

18 SAFETY REGULATIONS

18.1 Spare.

18.2 A boat that retires from a race shall notify the race committee as soon as possible.

19 REPLACEMENT OF CREW OR EQUIPMENT

19.1 Substitution of competitors will not be allowed without prior written approval of the race committee. Replacement of the responsible person is not allowed.

19.2 Substitution of damaged or lost checked and hallmarked equipment by not-checked equipment will not be allowed unless approved by the race committee. Requests for substitution shall be made to the committee at the first reasonable opportunity.

20 EQUIPMENT AND MEASUREMENT CHECKS

On the water, a boat can be instructed by the race committee or of the technical committee to proceed immediately to a designated area for inspection. Ashore, equipment may be inspected or measured at times specified in the class rules. See also Attachment B, NOR.

21 EVENT ADVERTISING

Spare.

22 OFFICIAL BOATS

Official boats will be marked as follows: V-6 flag.



23 [DP] SUPPORT BOATS

23.1 Team leaders, coaches and other support personnel shall stay outside areas where boats are racing from the time of the preparatory signal for the first class to start until all boats have finished or retired or the race committee signals a postponement, general recall or abandonment.

23.2 Spare.

24 TRASH DISPOSAL

Trash may be placed aboard support or official boats.

25 Spare

26 Spare

27 [DP] RADIO COMMUNICATION

Except in an emergency, a boat that is racing shall not make voice or data transmissions and shall not receive voice or data communication that is not available to all boats.

28 PRIZES

Helmsman of the winning boat of the championship acquire the title "Dutch Champion" and receive the accompanying medal(s) of the RNWA.

The responsible person of the winning boat acquires the Blue Pennant of the RNWA.

Helmsman of the boats that are places second and third acquire also medal(s) of the RNWA.

29 DISCLAIMER OF LIABILITY

Competitors participate in the regatta entirely at their own risk. See RRS 4, Decision to Race. The organizing authority will not accept any liability for material damage or personal injury or death sustained in conjunction with or prior to, during, or after the regatta.

30 RIGHTS TO USE NAME AND LIKENESS

By participating in this event, competitors automatically grant to the organizing authority and the event sponsors the right, in perpetuity, to make, use, and show, at their discretion, any photography, audio and video recordings, and other reproductions of them made at the venue or on the water from the time of their arrival at the venue, until their final departure, without compensation.

31 INSURANCE

Each participating boat shall be insured with valid third-party liability insurance with a minimum cover of Euro 1.500.000 per event or the equivalent.

32 ORGANISATION

The race officer is: Franc Schiet

The chairman of the protest committee is: Jack Aarts

The by the RNWA appointed technical committee is: Toon Neijman and Klaas Molenaar



Attachment A

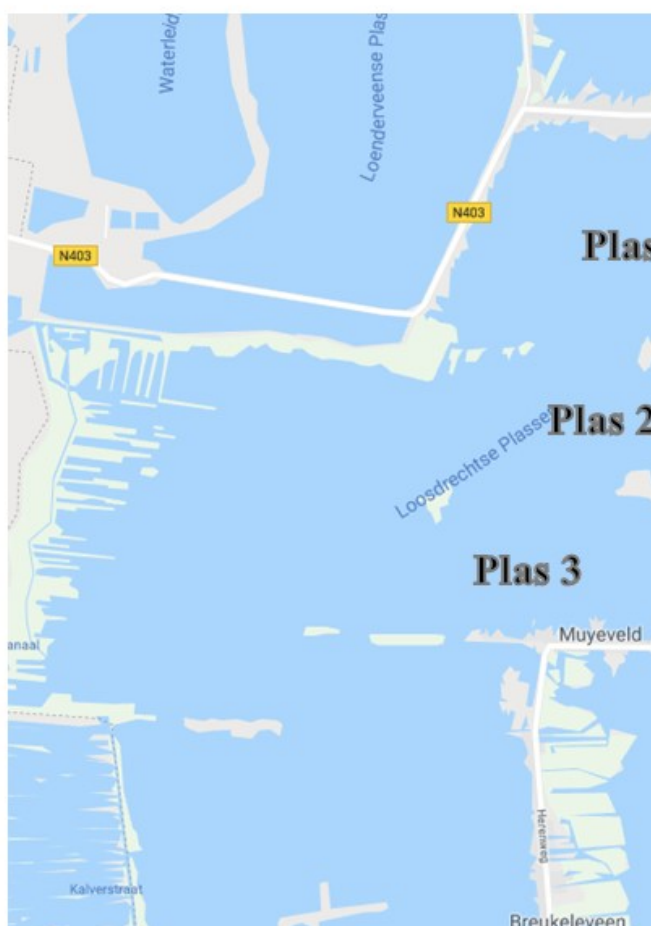

Attachment B
ILLUSTRATING THE COURSE

Trapezoid Courses

Outerloop, Group I and Gold Fleet
Start - 1 - 2 - 3 - 2 - 3 - 5 - Finish

Innerloop, Group II and Silver Fleet
Start - 1 - 4 - 1 - 2 - 3 - 5 - Finish

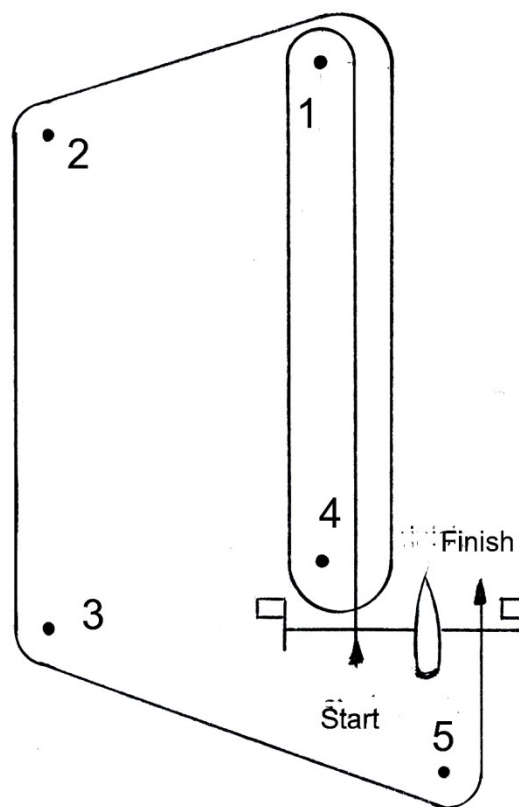
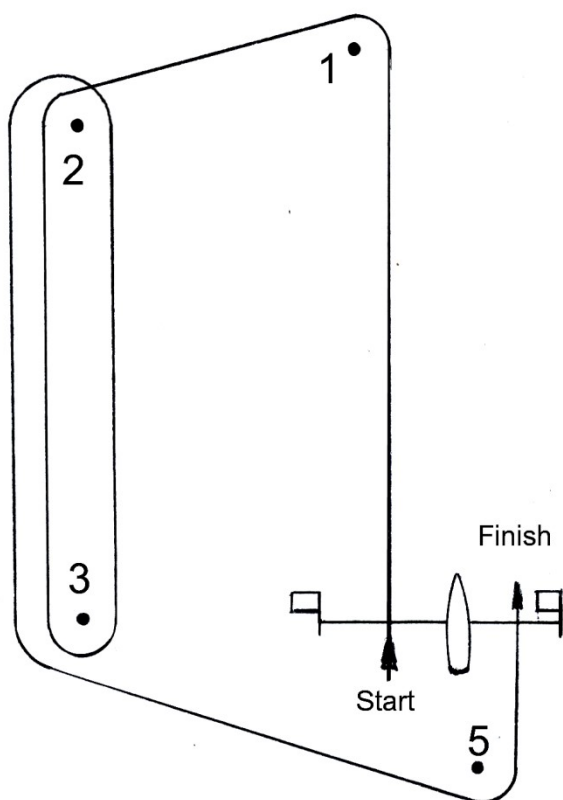



Appendix K; Qualifying Races

- a. De groups are composed on the basis of the results of the Dutch Championships/ Annual trophy of last year using the system:

group1	group 2	group 3	group 4
1	2	3	4
8	7	6	5
etc.			

Sailnumbers, not mentioned in the results of last year will be added in numeric order to the groups.

- b. In the qualifying races is the start of Group II- the amount of boats as stated in the Sailing Instructions- 5 minutes after a valid start of Group I. In the final races is the start of the Silver fleet the amount of boats as stated in the Sailing Instructions - 5 minutes after a valid start of the Gold fleet.
- c. The Sub Groups are sailing qualifying races according to this schedule:

Qualifying Race	Group I - Outerloop	Group II – Innerloop
1	Sub Groups a and b	Sub Groups c and d
2	Sub Groups b and d	Sub Groups a and c
3	Sub Groups a and d	Sub Groups b and c

- d. After the qualifying races boats will be assigned to final-series fleets Gold and Silver. If three qualifying races are completed, the worst result in the qualifying races will (temporarily) be discarded.
- e. There will be the same number of fleets in the final series as in the qualifying series. The final-series fleets will have, as nearly as possible, equal size but so that the Silver fleet is not larger than the Gold fleet based on the number of entries. Boats with the best qualifying-series ranks will race all final-series races in the Gold fleet, boats with the next-best qualifying-series ranks will race in the Silver fleet.
- f. As long as three qualifying races are completed the assignment to Gold- and Silver fleet will be posted 1 hour or more before warning signal next race.
- g. If after one day before the last day of racing only two qualifying races are completed, the assignment to the Gold and Silver fleet will be made after one day before the last day on the basis of two qualifying races. If after one day before the last day of racing only one qualifying race is completed, the qualifying series will be extended until two valid races are completed. If less than three qualifying races are completed, the ranking is based on the results without discard.
- h. Points for letter scores as mentioned in RRS A11 are the same as points given in the biggest possible fleet +1. This changes RRS A4.2 .
- i. Scores in the qualifying series are carried forward to the final series.